

# Electric Vehicle Charging Stations (EVCS)

## Goal

- To positioning the Village for the move toward more Electric Vehicles
- Encourage more people to the downtown business area
- Zero cost to the Village



## Municipal Zero-Emission Vehicle Infrastructure Grant

- Awarded \$9,790.00 in April 2023
- Awaiting Funds to be released by the Comptroller

# Electric Vehicle Charging Stations (EVCS)

- 1<sup>st</sup> Location:  
Southwest corner of the Mill Street Municipal Parking Lot

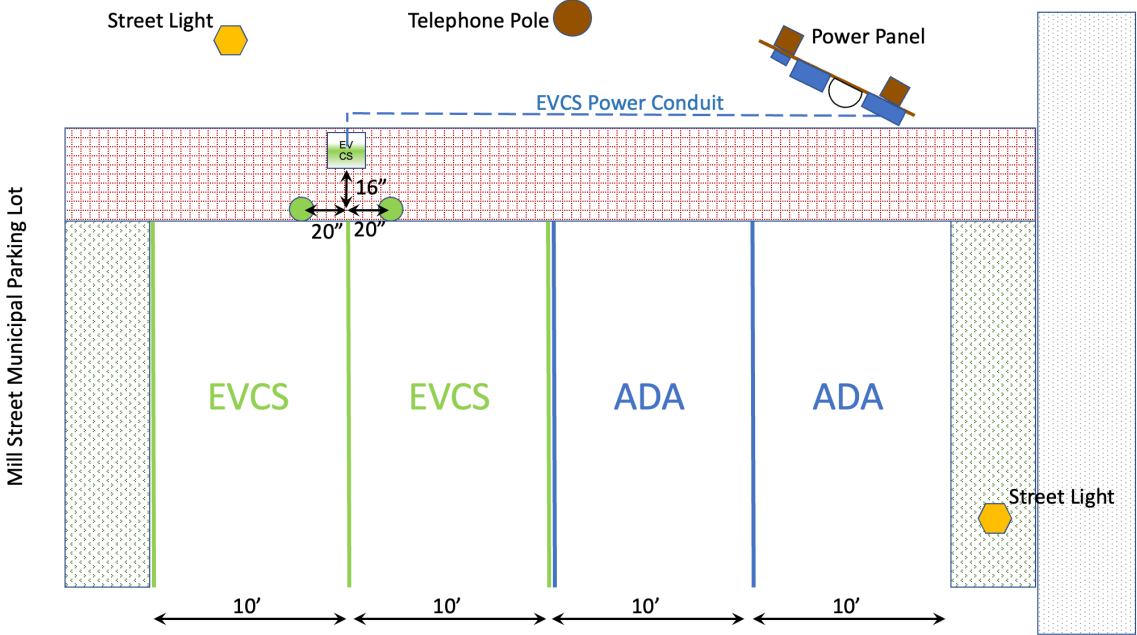

# Electric Vehicle Charging Stations (EVCS)



## ➤ Work Items

1. **Grant - Awaiting NYS Comptroller release of funds**
2. **Covenant (2 parking spaces) - Request submitted 17 August 2023**
3. **Village Law - Request submitted 06 July 2023**
4. **Insurance - Quote received**
5. **Electrician - Quote received**
6. **Trench, Signage, and Pavement Markings - Quote received**
  - Village Highway Dept to Assistance
7. **Permits and Inspections - Contingent on above**
8. **Vendor Selection - In process**

# Electric Vehicle Charging Stations (EVCS)

## ➤ VENDORS

- Started with 14
- Narrowed down to 4
  - FLO
  - EVBox
  - Juicebar
  - Lexington Energy Group

## ➤ Criteria

- Cost
- Reliability
- Management
- Return on Investment (RoI)



# Electric Vehicle Charging Stations (EVCS)

- Hardware
  - Physical Devices
  - Displays/User Interface
  - Self Retracting Cables
  - ADA Compliant
  - Durability
- Software
  - Open Source
  - User Interface Interaction
  - Billing Rate Management
  - Payments to Village
- Maintenance
  - Preventive Schedule
  - Repairs Process/Cost





# Electric Vehicle Charging Stations (EVCS)

- Possible future locations
  - Franny Reese Memorial Park
  - Village Hall
  - Patriots Park

